

Assembly Guide

60/30 – Steel shelving system



Assembly Guide

Assembly guide for 60/30 Steel Shelving System

Table of contents

Basic and pre-assembly	Page 3
Assembly of starters and adders	Page 4
Crossbars and upright extenders	Page 5
Closed base platters	Page 6
Wall strips	Page 7
Sloping shelves	Page 8
Book supports	Page 8
Wood end panels	Page 9

Care instruction for BCI shelving

Use a moist cloth to clean the shelves, uprights and panels. Note, do NOT use any chemicals what so ever. Use of harsh chemicals might destroy the protective lacquer.

Recycling information

Should be disposed of as recyclable metal.

Assembly Guide

Assembly guide for 60/30 Steel Shelving System

Basic Assembly:

Starter units consist of two uprights and two crossbars (84"/212 cm and 90"/229,5 cm high sections may require a third crossbar in each section, depending on the intended load; while heights above that should have three crossbars in any case).

Adder units consist of one upright and the quantity of crossbars as outlined above; and will be used in conjunction with starter units.

The uprights at the end of each range will use either crossbar fitting plates or end panel brackets opposing the crossbar on the other side of the upright.

If upright extenders are used, the extender should be installed into the uprights prior to installations of the crossbars; or if transverse bracing is used; the transverse brace fitting should be installed into the uprights before installation of the crossbars.

The range should be placed in its proper position on the floor plan, squared up, and leveled at this time. Install base plates next and make any adjustments necessary to the placement of the upright.

For heights 84"/212 cm and 90"/229,5 cm, shelf depth and intended use of the shelving may require either floor-mounting brackets (for double-faced shelving) or wall-mounting brackets (for single-faced shelving). For double-faced shelving higher than 90"/229,5 cm (with 10"/25 cm deep shelves or less) it is strongly recommended that "L" shaped floor mounting brackets be used; four for each interior upright and two for each upright at the ends of the ranges. The "L" bracket should be secured into the foot of the upright, and also into the floor using fasteners appropriate to the floor type, taking the shelving into consideration.

If transverse bracing is used, place the stabilizer tubes (60"/152 cm standard length) into the transverse bracing fitting, which were previously installed into the tops of the uprights (as described above), and fasten using the set-screw provided.

Install shelves and components into the section as required.

In cases where floor-mounting is not used, the shelving system may require further

minor leveling after it is loaded. This can be achieved by using an open-end wrench on the leveler nut.

Pre-Assembly:

Remove all the end caps in the upright tops. These caps will be re-installed once installation is completed.

Be sure that the depth of the shelf corresponds to the depth of the upright.

Assembly Guide

Assembly guide for 60/30 Steel Shelving System

Starter:

1. It is most practical to mount the bottom crossbar between the two uprights first and the top crossbar last. If there are three crossbars, build upwards by installing the center crossbar after the bottom crossbar.

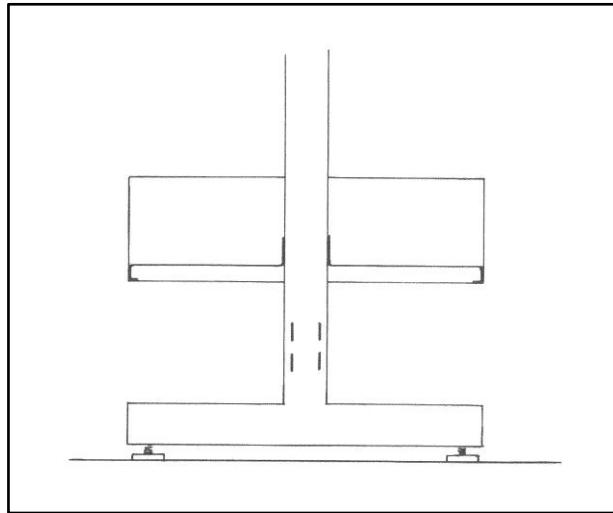

Adder:

1. Mount the bottom crossbar to the additional upright first and then mount the bottom crossbar to the starter section or other existing bays. Continue building upwards as you did prior with the starter.

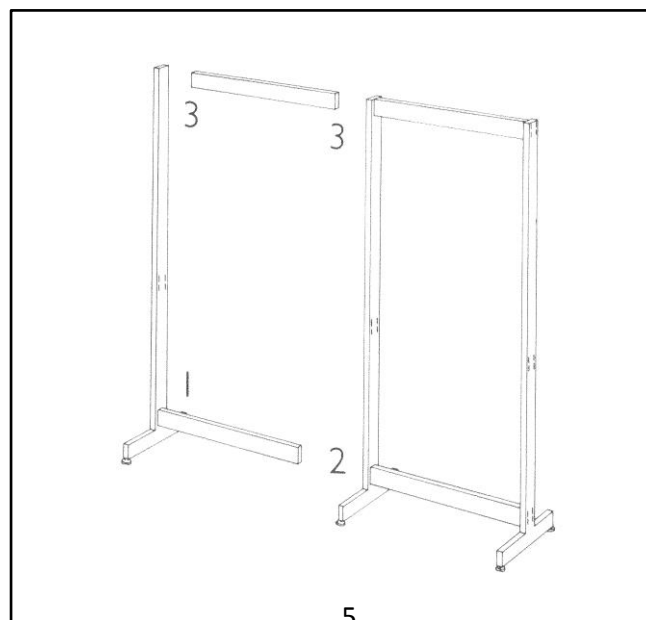

Assembly Guide

Assembly guide for 60/30 Steel Shelving System

Crossbar:

1. Install the bottom crossbar by aligning the hooks into the upright attachments and secure the crossbar into the locked position with a rubber mallet.
2. Install the top and center crossbar with the same method as the bottom crossbar.
3. Adjust the leveling guides once the shelving components are installed, so that the shelving is vertically and horizontally leveled and balanced. To adjust the leveling guides, use an open end wrench.
4. Use the same method of installation when single-faced shelving is specified.
5. If the shelving involves intermediate panels, you will install these when the section frame is completed, but before you install the various shelving components. See special section

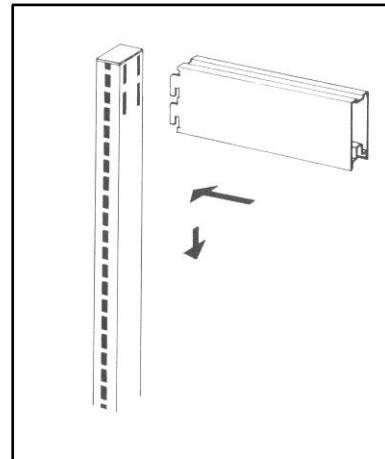
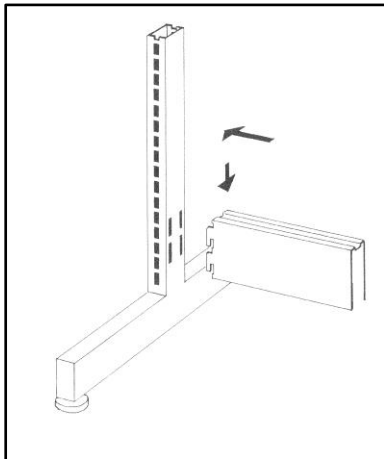

Upright Extenders:

1. Remove the top end cap of the upright and secure the upright extender into the top opening of the upright with a rubber mallet. Install the end cap into the extender.

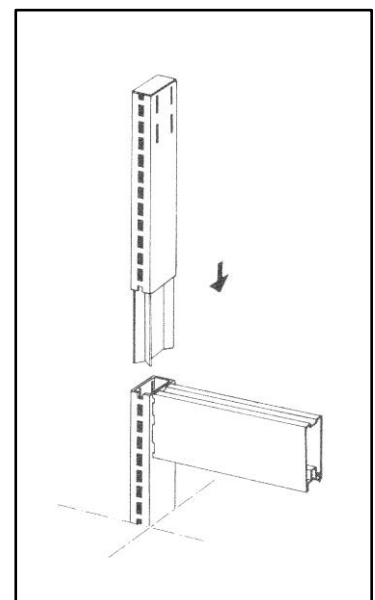

Assembly Guide

Assembly guide for 60/30 Steel Shelving System

Closed base platters

Double-faced end panels will be supplied with (2) "Z" fittings and (2) Key fittings.
Single-faced end panels will be supplied with (1) "Z" fitting and (1) Key fitting.

Schedule of equipment:

A	Base Plate
B	Component installed at base
C	Upright
D	Crossbar
E	"Z" fittings at base
F	Key fittings at top

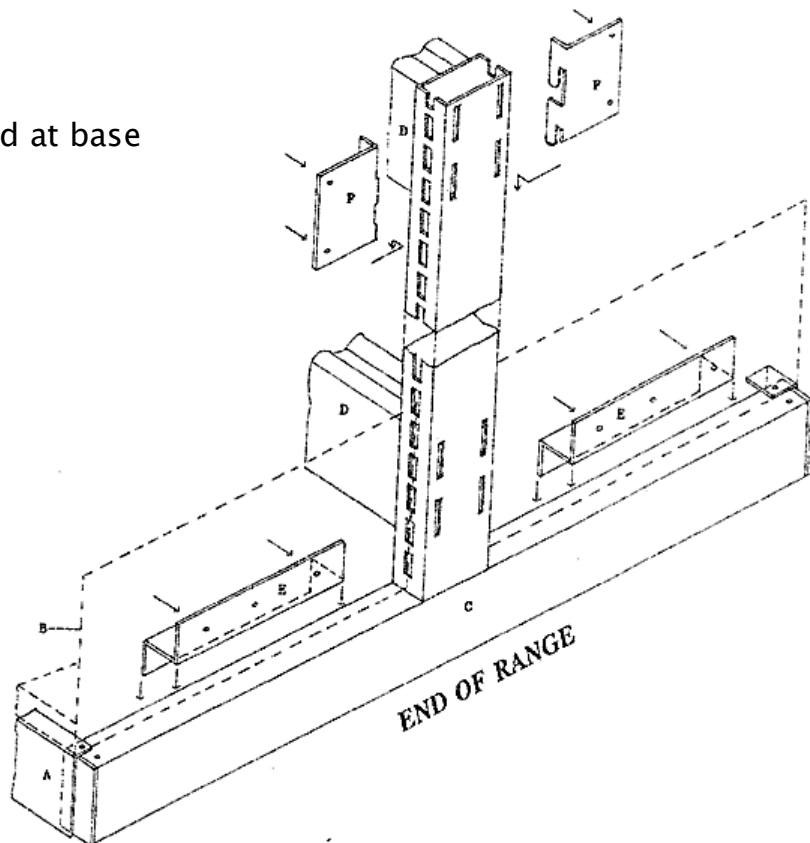

Installations instructions:

1. To gain access, remove COMPONENT (B) installed at the base of the shelving unit.
2. Place base "Z" FITTING "E" on top of the upright foot with the wood screw holes aligning with the outer side of the upright.
3. Place the KEY FITTINGS "F" into the four exposed crossbar slots located at the top of the upright. Make sure the hooks have fully dropped into position.
4. Shim the wood end panel into position against the upright. Visually check that all steel components are covered by the panel and that the panel is leveled.
5. Using wood screws and an electrical drill secure the panel to the BCI fittings and tighten. You may wish to secure the panel at the bottom first and adjust if need prior to attaching the panel at the top. You may wish to align the panel, transfer the placement of the holes, and drill pilot holes prior to full installation.

Assembly Guide

Assembly guide for 60/30 Steel Shelving System

Wall Strips:

1. Mount the wall strips 2" above finished base.
2. Turn the wall strip so that the end with half of a hole is upwards (towards the ceiling).
3. The center distance from wall strip to wall strip must be the width as the shelves (30"/75 cm., 36"/90 cm., 39"/100,5 cm.) In order to find the correct distance you can use 4 brackets (2 left and 2 right) and one shelf.

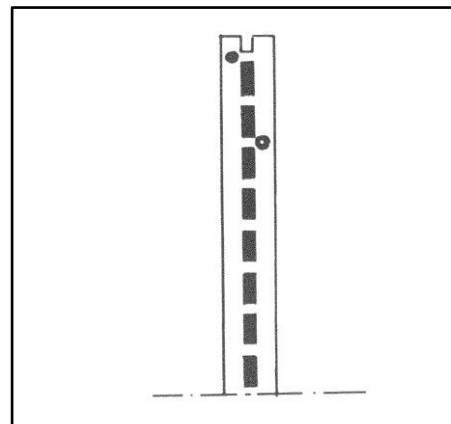
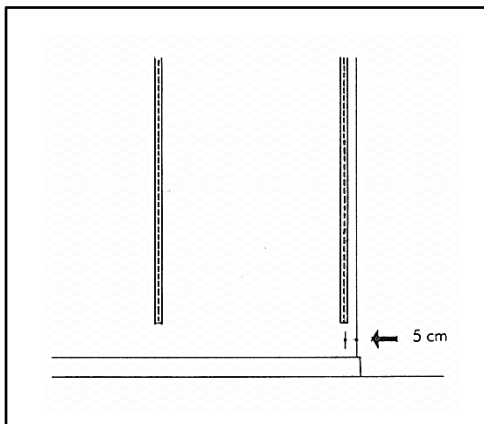

Procedure:

1. Mount one wall strip at the desired starting point on the wall. Hook in two brackets (1 left and 1 right) in the same holes, approximately in the middle of the wall strip.
2. Insert the two remaining brackets into a free wall strip at the same height increments as the other brackets.
3. By holding the free wall strip against the wall, and placing the shelf into the brackets the distance is correct.
4. Control the horizontal leveling by placing a spirit level on the shelf.

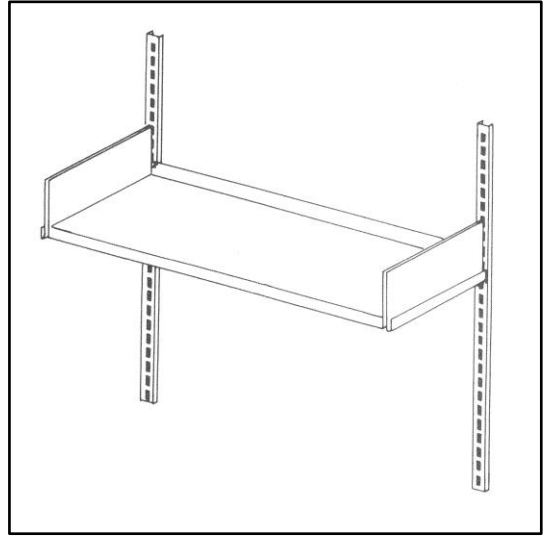
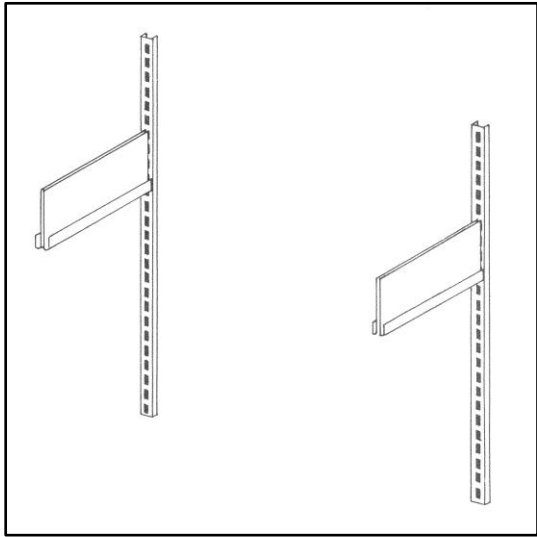

Assembly Guide

Assembly guide for 60/30 Steel Shelving System

Sloping Shelves:

1. Hook on the fittings into the shelf, and suspended the shelf at the desired location on the upright as shown on the figure. When several sections are specified with sloping shelves, we suggest starting from the center of the range and work outward evenly.

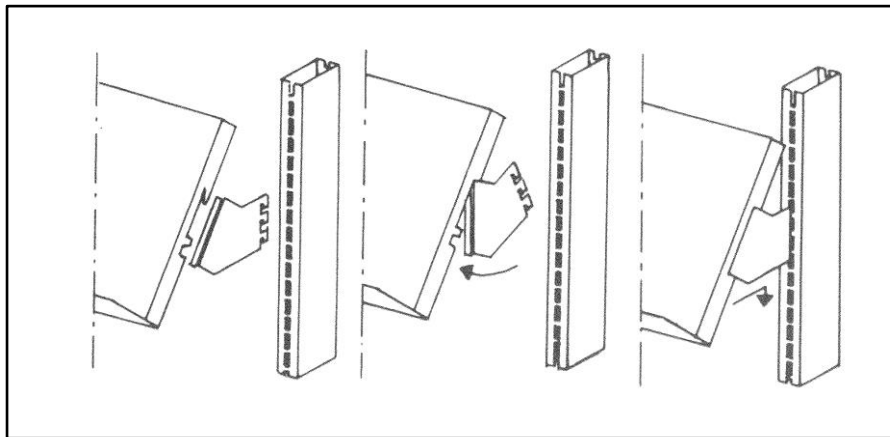

Book Supports:

Mount the back edge book support by tilting the plastic fitting over the edge of the shelf and twisting into place.

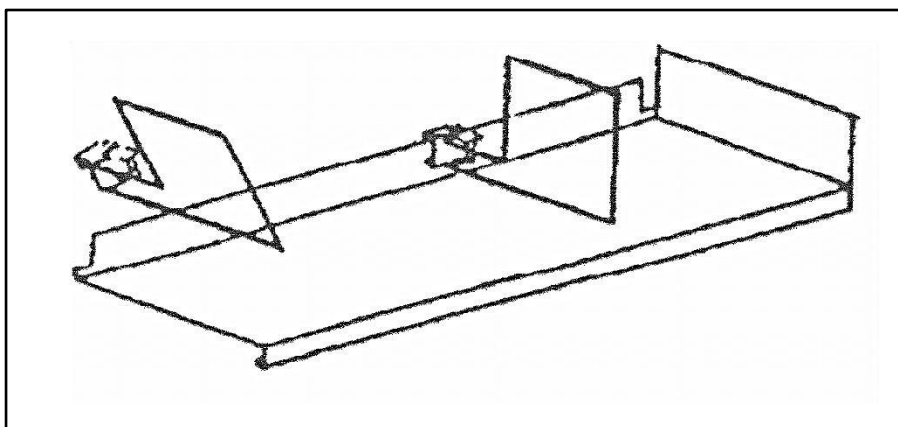

Assembly Guide

Assembly guide for 60/30 Steel Shelving System

Wood end panels

1. When installing wood end panels, insert the top fittings into the upper crossbar slots and place the “Z” brackets over the foot of the upright.
2. Please note, if the shelving is completely assembled, any base shelves and canopy tops will need to be removed to gain access for installation.
3. The panels perimeter is slightly larger than the shelving. Centre the panel to the edges of the shelving from top to bottom and side to side and mark the holes for drilling.
4. Remove the fittings and “Z” brackets from the shelf, align them over the marked holes on the panel and use $\frac{1}{2}$ to $\frac{3}{4}$ long wood screws and secure them in position. Please make sure the wood screws do not exceed the thickness of the wood end panel. It is also advised that the installer predrill the holes with a small drill prior to using wood screws. This will reduce the chance of wood splitting or shattering.
5. At this point, the panel with attached fittings can be installed onto the shelving and any removed shelving components can be reinstalled.

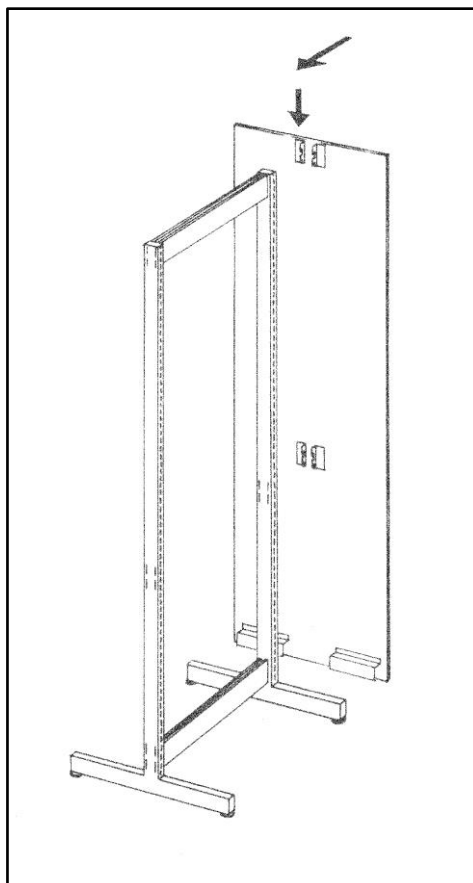



WE ARE LIBRARY PEOPLE®



DENMARK

Lammhults Biblioteksdesign A/S
Dalbækvej 1
6670 Holsted

bci@bci.dk
www.lammhultsbiblioteksdesign.dk

SWEDEN

Lammhults Biblioteksdesign AB
Åkergränden 7
221 00 Lund

eurobib@eurobib.se
www.lammhultsbiblioteksdesign.se

NORWAY

BS Eurobib AS
Postboks 6348
Malerhaugveien 20
0604 Oslo

post@bseurobib.no
www.bseurobib.no

GERMANY

Schulz Speyer Bibliothekstechnik AG
Friedrich-Ebert-Straße 2a
67346 Speyer

sales@schulzspeyer.de
www.schulzspeyer.de

FRANCE

BC Interieur S.A.R.L.
8, Allée Lorentz
77 420 Champs sur Marne

bci@bcinterieur.com
www.bcinterieur.fr

UNITED KINGDOM

thedesignconcept Ltd.
Unit 12, Evans Business Centre
Belgrave Street
Bellshill ML4 3NP

info@thedesignconcept.co.uk
www.thedesignconcept.co.uk

BELGIUM/HOLLAND

SBNL – Schulz Benelux BVBA
Appelweg 94 C
3221 Holsbeek

info@sbnl.be
www.sbnl.be

Find our dealers on www.wearelibrarypeople.com

SCHULZ
SPEYER